



Indirect-Fired Storage Water Heater

Models HWT-40, HWT-60, HWT-80

INSTALLATION AND OPERATING INSTRUCTIONS

Contents	Page
I Safety	2
II Product Selection	3
III Performance Ratings/Specs	4
IV Installation/Piping	5-8
V Wiring	9-13
VI Maintenance	14
VII Warranty	15-16

Heater Package includes:

- Fully insulated oven glazed titanium glass lined tank with temperature control well installed.
- Temperature control adjustable up to 145°F.

WARNING - HOT WATER CAN SCALD!

Read all of the following important warnings to avoid the possibility of personal injury, death, or property damage.

WARNING TO THE USER:

- Keep temperature control on heater at lowest setting which is satisfactory.
- Always adjust water temperature from taps by starting with a cool mix of water and gradually bring to warmer temperature.
- Never leave children, elderly or disadvantaged persons unattended where hot water taps are located.

WARNING TO THE INSTALLER AND SERVICEPERSONS:

- Keep temperature control on heater at lowest setting which is satisfactory.
- Installation of a temperature and pressure relief valve of the proper rating for the heater tank size is required.
- Install a tempering device, such as a mixing valve, on hot water piping which feeds areas where high temperature water is not demanded.
- When servicing this installation, make sure drain connections are tight and drain hose is directed away from all persons or areas where injury or damage can occur.



I SAFETY

The warranty on this water heater is in effect only when the water heater is installed and operated in accordance with these instructions. The manufacturer of this water heater will not be liable for any injury or property damage resulting from failure to comply with these instructions.

WARNING! This water heater must be installed strictly in accordance with the instructions enclosed, and local electrical, fuel and building codes. It is possible that connections to the water heater, or the water heater itself may develop leaks. IT IS THEREFORE IMPERATIVE that the water heater be installed so that any leakage of the tank or related water piping is directed to an adequate drain in such a way that it cannot damage the building, furniture, carpeting, adjacent areas, lower floors of the structure or other property subject to water damage. This is particularly important if the water heater is installed in a multi-story building, on finished flooring or carpeted surfaces. SLANT/FIN CORP. CANNOT BE HELD LIABLE for damage caused by water from the water heater, pressure relief valve, or related fittings. Closets without drains and carpeted areas are examples of unsuitable locations for any water heater. Select a location as centralized within the piping system as possible. The heater should be located in an area not subject to freezing temperatures at any time. It is recommended that a suitable drain pan be installed under the water heater. This pan shall be a minimum of 50mm (2 in.) deep and have a diameter that is a minimum of 50mm (2 in.) greater than the diameter of the water heater. Suitable piping shall connect the drain pan to a properly operating floor drain.

Relief Valve Requirements

Caution: To reduce the risk of excessive pressures and temperatures in this water heater, install temperature and pressure protective equipment required by local codes. It should be no less than a combination temperature and pressure relief valve certified by a nationally recognized testing laboratory that maintains periodic inspection of production of listed equipment or materials, as meeting the latest edition of ANSI Z21.22: Requirements for Relief Valves and Automatic Gas Shut-off Devices for Hot Water Supply Systems. This valve must be marked with a maximum set pressure not to exceed the marked MAXIMUM working pressure of the water heater (150 PSI). Install the valve into an opening provided and marked for this purpose in the water heater, and orient it or provide tubing so that any discharge from the valve will exit only within 6 inches above, or any distance below the structural floor and cannot contact any live electrical part. The discharge opening must not be blocked or reduced in size under any circumstances. The end of the relief pipe opening should terminate near a floor drain or other suitable location not subject to blocking or freezing. DO NOT thread, plug or cap the relief pipe opening.

DANGER



- Water temperatures over 125°F can cause severe burns instantly, or death from scalds.
- Children, disabled, and elderly are at the highest risk of being scalded.
- See instruction manual before setting temperature at water heater.
- Feel water before bathing or showering.
- Temperature limiting valves are available, see manual.

NOTICE

The Indirect-fired water heater is deemed to be used in a "commercial setting" if at any time the unit is operated at a temperature over 150°F. Refer to warranty for additional information.

II PRODUCT SELECTION / PERFORMANCE

1. The following guidelines apply to residential systems only. For commercial or institutional installations contact the factory directly for assistance.

2. Determine the quantity of domestic hot water required. Factors to consider:

a. Estimate typical peak hour demand. Determine the general time of day (morning, noon, evening) when the most hot water is used. Use chart below to determine potential maximum usage.

Estimate of Peak Domestic Hot Water Usage

Use	Average Gallons of Use Hot Water per Usage	Times Used During One Hour	Times Used During One Hour
Shower	20	X _____	= X _____
Bath	20	X _____	= X _____
Shaving	2	X _____	= X _____
Hands and Face Washing	4	X _____	= X _____
Hair Shampoo	4	X _____	= X _____
Hand Dish Washing	4	X _____	= X _____
Automatic Dish Washing	14	X _____	= X _____
Food Preparation	5	X _____	= X _____
Wringer Clothes Washer	26	X _____	= X _____
Automatic Clothes Washer	32	X _____	= X _____
Total Peak Hour Demand			= _____

b. Estimate unusual peak draw demand. Whirlpool baths, hot tubs, and multiple head showers require large quantities of hot water in a short period of time. Contact fixture manufacturer for quantity of water required. Generally speaking, these circumstances can only be met with larger storage volumes.

c. Domestic Water Temperature. Most residential usage will be satisfied with 119°F water, the temperature setting recommended by the Consumer Product Safety Commission. Some applications such as laundry and dishwashers may require a higher temperature.

Ratings can be improved by increasing thermostat setting and using a mixing valve to temper the hot water to the proper temperature. When temperatures greater than 119°F are required, use a mixing valve at the outlet of the water heater or anti-scald fittings at point of use.

PERFORMANCE RATINGS	HWT-40	HWT-60	HWT-80
CAPACITY (Gallons)	40	55	79
HEAT EXCHANGER SURFACE AREA SQ.FT.	14	14	26
RECOMM. FLOW RATE GPM (Boiler Water)	10	10	14
PRESSURE DROP FT. HD. (Heat Exchanger)	2.3	2.3	11
FIRST HR. RATINGS GPH 90 DEGREE RISE	188	225	295
CONTINUOUS FLOW GPH 90 DEGREE RISE	160	187	240
FIRST HR. RATINGS GPH 70 DEGREE RISE	233	277	363
CONTINUOUS FLOW GPH 70 DEGREE RISE	205	239	308
BOILER SIZE BTU'S REQUIRED	120,000	140,000	180,000

NOTE: ABOVE RATINGS BASED ON BOILER MAINTAINING TEMPERATURE OF 180 DEGREES FAHRENHEIT.

III TANK SPECIFICATIONS

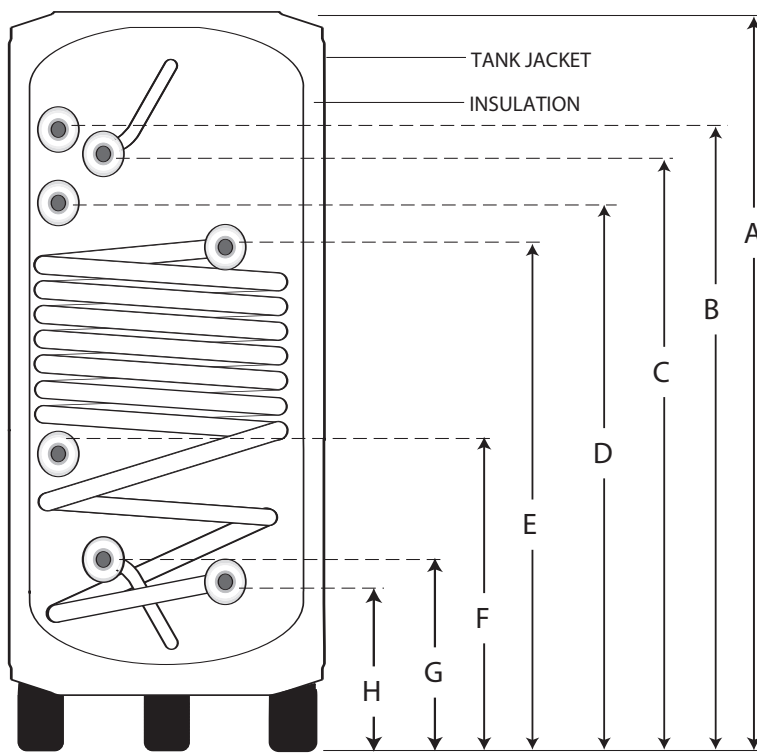

KEY	
A	TANK TOP
B	TEMP. & PRESS. RELIEF VALVE
C	DOMESTIC HOT WATER OUTLET
D	RECIRCULATION(HWT-80)
E	BOILER WATER INLET(SUPPLY)
F	CONTROL
G	DOMESTIC COLD WATER INLET
H	BOILER WATER OUTLET(RETURN)

MODELS: HWT-40, HWT-60, HWT-80

PHYSICAL SPECIFICATIONS

MODEL	DIAMETER OF TANK	VOLUME (Gallons)	HEIGHT TO CONNECTION (Inches)								COIL SURFACE (Sq. Ft.)	WEIGHT (Lbs.)		
			A	B	C	D	E	F	G	H		NET	SHIPPING	FILLED
HWT-40	20"	40	45	37-1/4	35-5/8	N/A	35	20	10-7/16	8-7/8	14	116	124	449
HWT-60	20"	55	58	49-5/8	48	N/A	35	20	10-7/16	8-7/8	14	118	143	576
HWT-80	22"	79	71	61-1/2	61-1/4	47-7/8	54-5/8	40-1/4	10-7/8	10-1/4	26	232	243	737

CONNECTIONS

DESCRIPTION	MODEL		
	HWT-40	HWT-60	HWT-80
TEMP. & PRESS. RELIEF VALVE	3/4"	3/4"	1"
DOMESTIC HOT WATER OUTLET	3/4"	3/4"	1"
DOMESTIC COLD WATER INLET	3/4"	3/4"	1"
BOILER WATER OUTLET (RETURN)	1"	1"	1"
CONTROL	1/2"	1/2"	1/2"
BOILER WATER INLET (SUPPLY)	1"	1"	1"
RECIRCULATION (HWT-80)	-	-	3/4"

NOTES: All fittings are female NPT thread connections.

IV INSTALLATION/PIPING

The Location of the heater.

Locate the heater so that there is easy access to the control, piping, valves, drain and heater for future servicing and maintenance. The heater is to be kept in an area where it is not exposed to freezing temperatures.

Also, the heater must be located in an area where a leak (eg. from the piping or fittings, from any temperature and relief valve discharge, or from the tank itself), will not cause personal harm or damage the surrounding area. The tank should be installed in an area with a floor drain or in a pan suitable for water heaters.

Slant/Fin will not be held liable for any damages caused by water leakage.

The floor or area where the tank is installed must be capable of supporting the tank when filled with water. (Refer to Table at right.)

Read the Installation and Operating Instructions manual thoroughly. Follow recommended piping and wiring diagrams. Upon completing installation, fill the tank with water. While filling it leave a hot water faucet open until a steady stream of water is flowing. Then, shut the faucet and check for any leaks throughout the entire system.

TANK WEIGHT WHEN FILLED

Model	Weight (lbs.)
HWT-40	449
HWT-60	576
HWT-80	737

FOR YOUR SAFETY: Do not store or use gasoline or other flammable vapors or liquids in the vicinity of this or any other appliance. Controls on this appliance could ignite vapors causing an explosion

PIPING

1. General

a. All plumbing must be in accordance with the requirements of the authority having jurisdiction.

b. Use both thread tape and pipe dope on all mechanical connections.

c. Zone valve (if used) and circulator must be sized to provide minimum flow rate specified in the table to the right, Flow Specifications. Use 1 inch nominal copper tubing between boiler and heat exchanger. See the tables on Friction Loss. Point of emphasis: using a zone valve without a full bore may cause high pressure drop which will adversely affect performance. Use extreme care when selecting zone valve.

d. All piping must be adequately supported.

e. Allow for thermal expansion.

f. Dielectric Unions (recommended)-used to electrically isolate the tank from the connected domestic water piping. This helps to minimize the possibility of corrosion damage.

Flow Specifications

Model No.	Recommended Flow Rate	Heat Exchanger Pressure Drop (Ft. Hd.)	Domestic Water Connection Sizes
HWT-40	10 GPM	2.3	3/4"
HWT-60	10 GPM	2.3	3/4"
HWT-80	14 GPM	11	1"

Notes: All fittings are female NPT thread connections

Friction Loss 100 Feet of Tubing (psi)

Tubing Type	Flow Rate (gpm)	
	10 gpm	15 gpm
Type K	3.1 psi	6.5 psi
Type L	2.7 psi	5.7 psi
Type M	2.3 psi	4.7 psi

Friction Loss Allowance for Copper Fittings (feet of straight tubing)

Fitting	Wrought	Cast
90° Elbow	1	4
45° Elbow	1	2
Tee, Run	1/2	1/2
Tee, Branch	3	5
90° Bend	2	-
180° Bend	2	-
Gate Valve	-	1

IV INSTALLATION/PIPING (cont'd)

PIPING

2. Domestic Water

a. Cold Water In. Install brass tee and drain valve (not provided). Install shutoff valve between water supply and cold water inlet for ease of service as shown in the exhibit below.

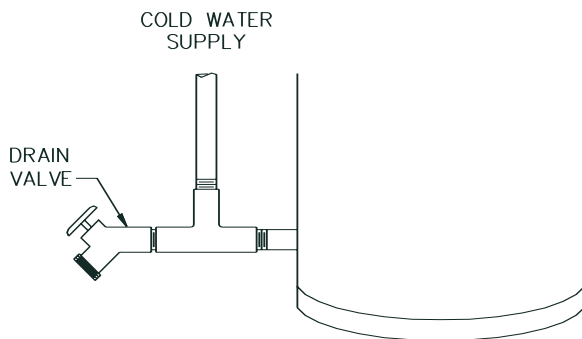

b. Standard Domestic Hot Water Out. A heat trap will improve energy efficiency by reducing piping heat loss.

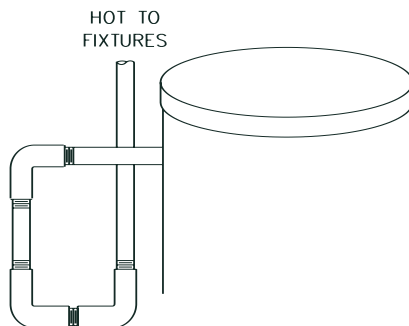

Thermostatic Mixing Valve

At times a thermostatic mixing valve may be recommended or required. The thermostatic mixing valve blends domestic cold water with hot water exiting from the heater, to yield a more constant desired temperature. Risk of scalding is not eliminated with the use of a thermostatic mixing valve. Refer to literature provided by valve manufacturers for recommended installation.

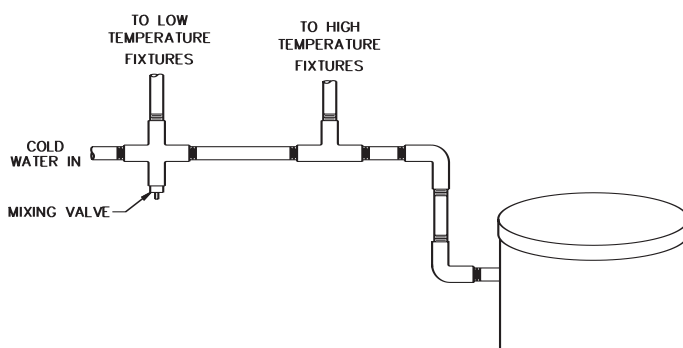

Expansion Tank

When a back flow device or no return valve is installed in the system a Thermal Expansion Tank designed for use with potable water will be required. Locate the expansion tank on the domestic cold water line near the heater between the back flow device or no return valve and the heater (see piping diagrams). Refer to the Thermal expansion Tank manufacturer literature for sizing.

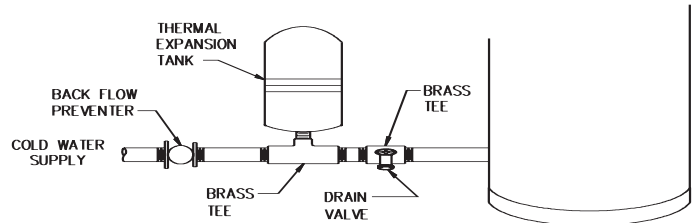

Vacuum Breaker

Slant/Fin recommends that a vacuum breaker be installed on the domestic piping to the heater. The vacuum breaker protects the heater in the event that tank pressure falls below atmospheric pressure.

Temperature & Pressure Relief Valve(T & P)

A T & P is required on all heaters. Install a T & P valve (long element type) into the separate tapping designated for the T & P.

Install temperature and pressure protective equipment required by local codes, but no less than a combination temperature and pressure relief valve certified as meeting the requirements for relief Valve and Automatic Shutoff Devices for Hot Water systems, ANSI Z21.22, by a nationally recognized testing laboratory that maintains periodic inspection of listed equipment or materials.

The valve must be oriented, provided with tubing or otherwise installed so that discharge can exit only within six (6) inches above, or at any distance below, the structural floor, and cannot contact any electrical part. The valve must be piped to an area where discharge will not cause personal injury or damage the surrounding area.

WARNING!

INSTALL A T & P WITH A RATED CAPACITY THAT IS EQUAL TO OR GREATER THAN THE OUTPUT OF THE ENERGY SOURCE.

REMOVAL OF THE T & P, OR FAILURE TO REPLACE TEMPERATURE- PRESSURE RELIEF VALVE, WILL RELEASE THE MANUFACTURER FROM ANY CLAIM WHICH MIGHT RESULT FROM EXCESSIVE TEMPERATURES AND PRESSURES.

IV INSTALLATION/PIPING (cont'd)

PIPING

TANK INSTALLATION

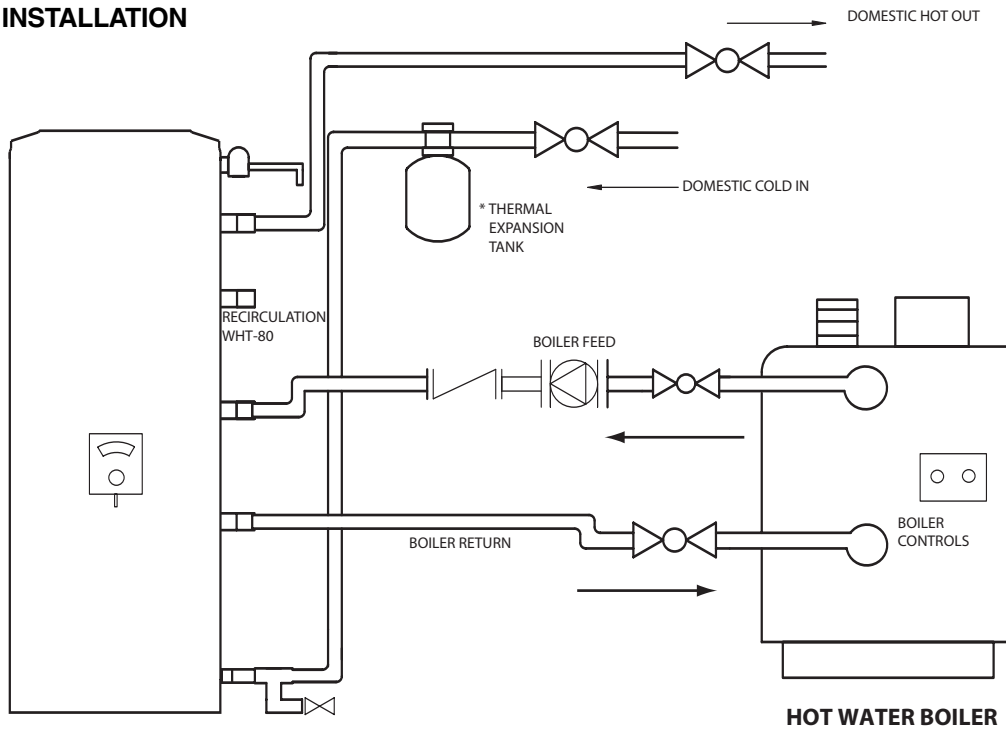

MULTIPLE TANK INSTALLATION

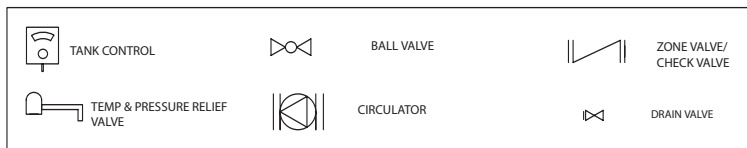
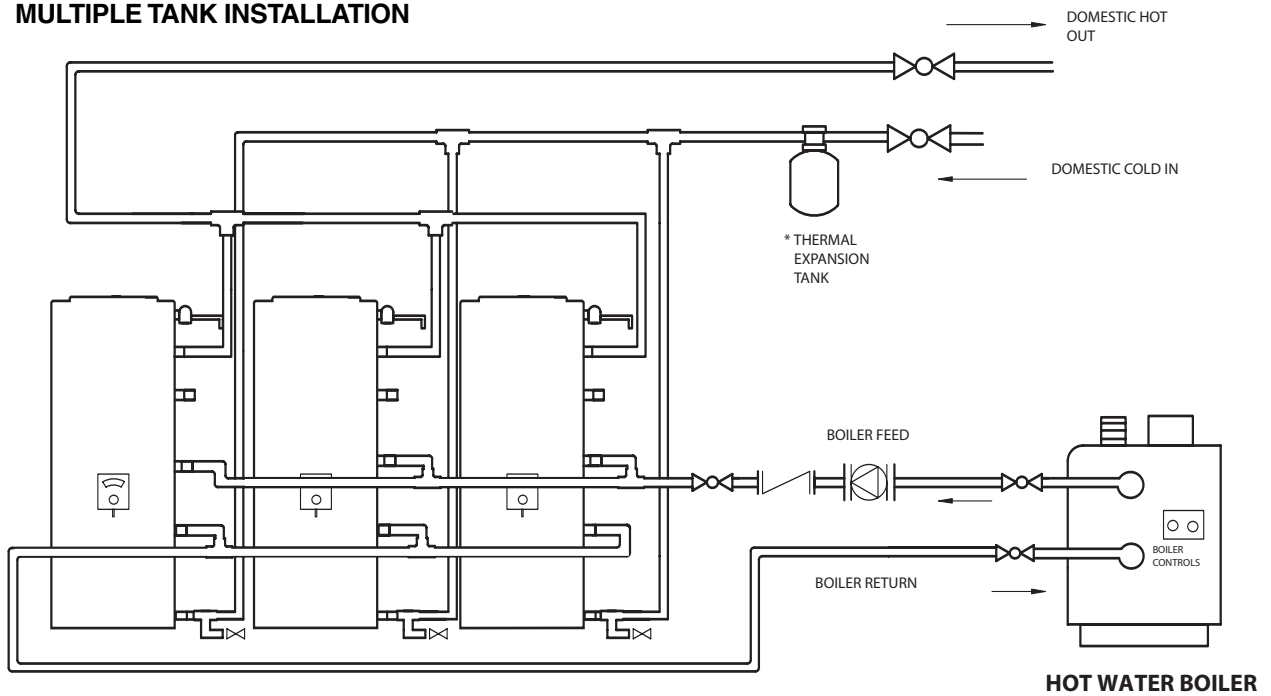

Notes: Thermal Expansion Tank is required whenever a backflow preventer or no return valve is present in the system. Locate the Thermal Expansion Tank on the Domestic Cold water line between the heater and backflow preventer or no return valve.

IV PIPING DIAGRAM AND INSTRUCTIONS FOR USE WITH A STEAM BOILER

INSTALLATION:

Install valves B and C a minimum of 6" below water line G. Keep valves as close to the boiler as possible. Install boiler drains D and E as close as possible to valves B and C.

FILL AND PURGE:

Close valves B and C. Attach a hose from an independent water source to boiler drain E. Attach a hose to boiler drain D leaving open end of hose in an empty bucket or basin. Open boiler drain E and D and allow water to fill coil of tank. Continue to allow water to flow until the flow is free of air. (smooth, non-sputtering flow) Close boiler drain D and then boiler drain E.

Open valves B and C and observe boiler water level at the gauge glass making sure that it remains at its original level. Fill the potable water side of the tank and purge air from tank by opening a hot water faucet.

When the power is switched on, the tank aquastat will turn on pump F and when the temperature of the boiler falls below the set-point, the boiler will fire

- | | |
|---|-----------------------------|
| A | Flow control valve |
| B | Ball or gate valve |
| C | Ball or gate valve |
| D | Boiler drain |
| E | Boiler drain |
| F | Permanently lubricated pump |
| G | Water level |
| H | Tank Aquastat |
| I | Boiler Aquastat |

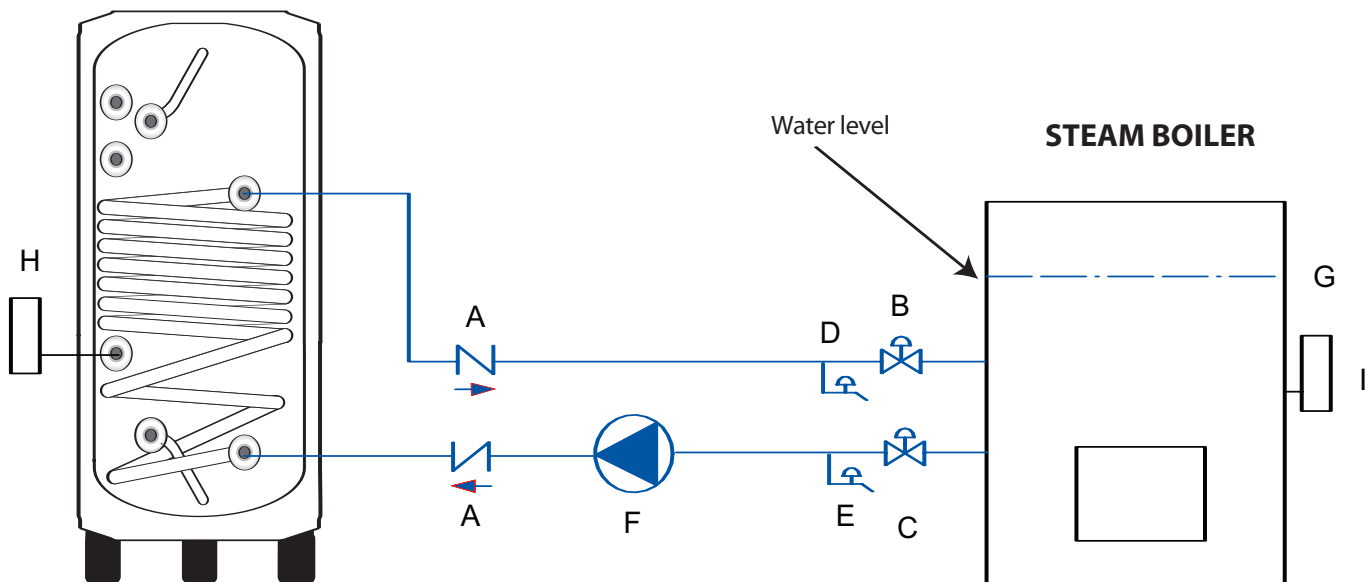

NOTE: When installing the Slant/Fin Indirect Water Heater with a steam boiler, the water flow (direction) is reversed through the tank coil (heat exchanger). The boiler water enters at the bottom of the coil and exits from the top of the coil. At no time should live steam be used in the tank coil (heat exchanger).

V WIRING

General wiring requirements

Wiring must conform to National Electrical Code in U.S.A., C.S.A. C22.1 Canadian Electrical Code Part 1 in Canada, and any other national, provincial, state, or local code requirements having jurisdiction.

All line voltage wiring must be a minimum 18 gage. A separate service switch for the water heater electrical circuit is recommended. This switch must not turn off the boiler or other components in the heating system.

IMPORTANT NOTE:

All wire connections to "T-T" or "A-A" terminals on boiler control must be from an isolated circuit which does not carry voltage from an external source. Any component which does not have isolated end switches must not be used unless a relay is added with the dry contacts wired to these terminals.

The Slant/Fin Indirect Tank heater operates in much the same way as an additional heating zone, either utilizing the same circulator as household heating or its own circulator. The heater temperature is maintained by the use of an immersion type aquastat. The aquastat is installed into the immersion well on the heater and secured by tightening the set screw or clamp.

The aquastat operates in much the same way as a thermostat. When the temperature falls inside the tank the set of contacts make (close) and when the temperature rises the contacts break (open).

The aquastat should be tied into the boiler system and controls. When the tank calls for heat the aquastat contacts close and signal the boiler controls, allowing the boiler to maintain temperature and proper operation of the tank circulator.

Slant/Fin recommends the use of a priority control to help the boiler maintain desired temperature and satisfy the tank's BTU requirements.

The Slant/Fin Indirect tank heater recovery ratings are based on the boiler's ability to maintain 180 degrees Fahrenheit. It is important that the installer, plumber or heating technician responsible for installing the heater, make certain that the boiler capacity (BTU) is adequate to satisfy the heater's BTU requirements.

DANGER



Water temperature over 125°F. can cause severe burns instantly or death from scalds.

Children, disabled and elderly are at highest risk of being scalded.

See instruction manual before setting temperature at water heater.

Feel water before bathing or showering.

Temperature limiting valves are available, see manual.

V WIRING (cont'd)

TANKLESS COIL BOILER APPLICATION - PRIORITY FIGURE 3

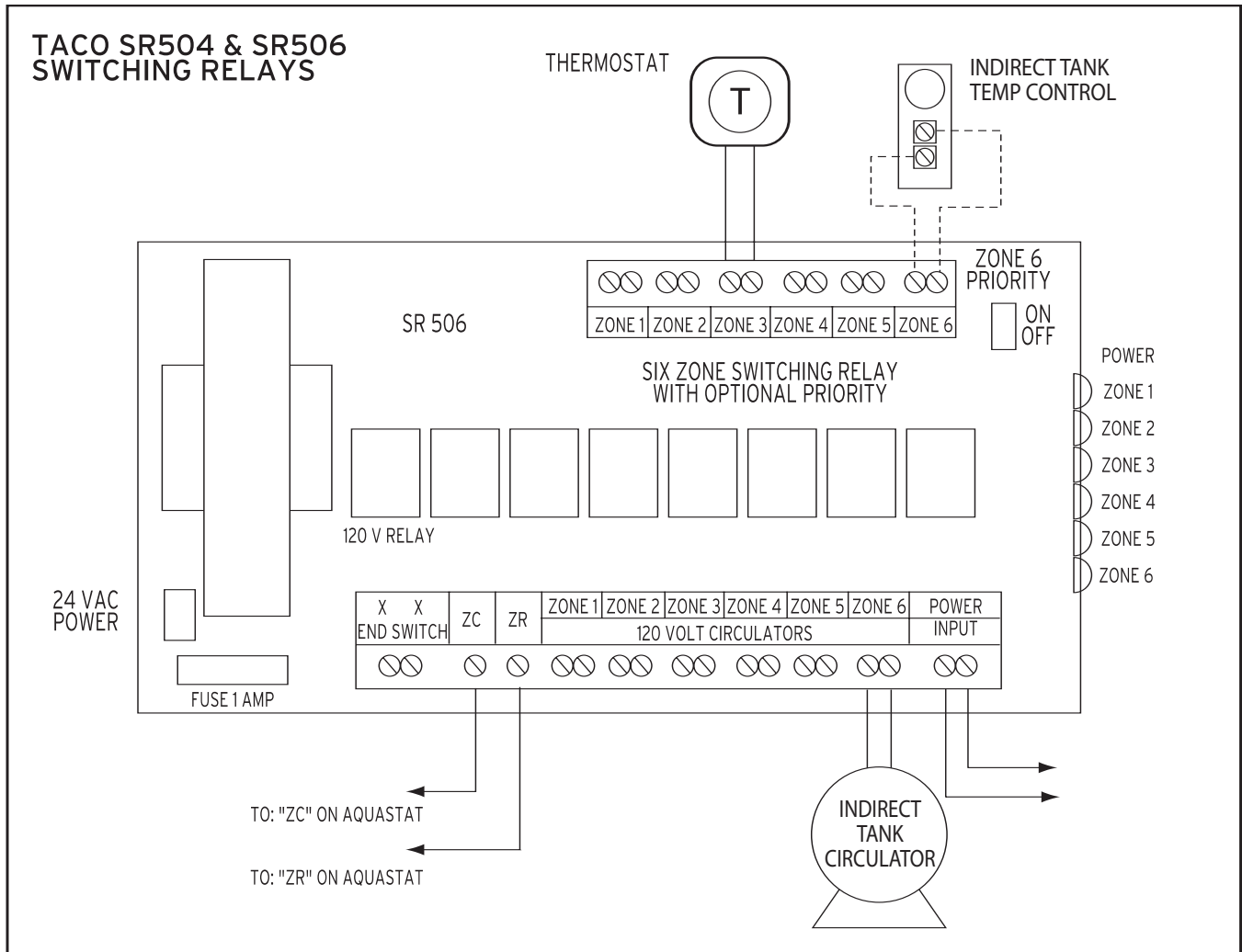

Operation: When any thermostat calls for heat, the boiler is given a signal to start. The appropriate circulator is energized only when the boiler temperature is above the set low limit.

Priority Operation: When zone 6 is switched to the priority setting and is actuated, all other zones will stop operation until zone 6 is satisfied. When zone 6 is not switched to priority, all zones will operate independently.

Jumper Placement: REMOVE the jumper between terminals ZC and ZR. Connect terminal ZC to ZC terminal on the aquastat control. Connect terminal ZR to ZR terminal on the aquastat control. Confirm polarity is consistent between boiler aquastat and switching relay.

Power Input: Connect 120 volt as power input to terminals N and H. Neutral wire to terminal N. Hot wire to terminal H.

V WIRING (cont'd)

COLD START BOILER APPLICATION - PRIORITY FIGURE 4

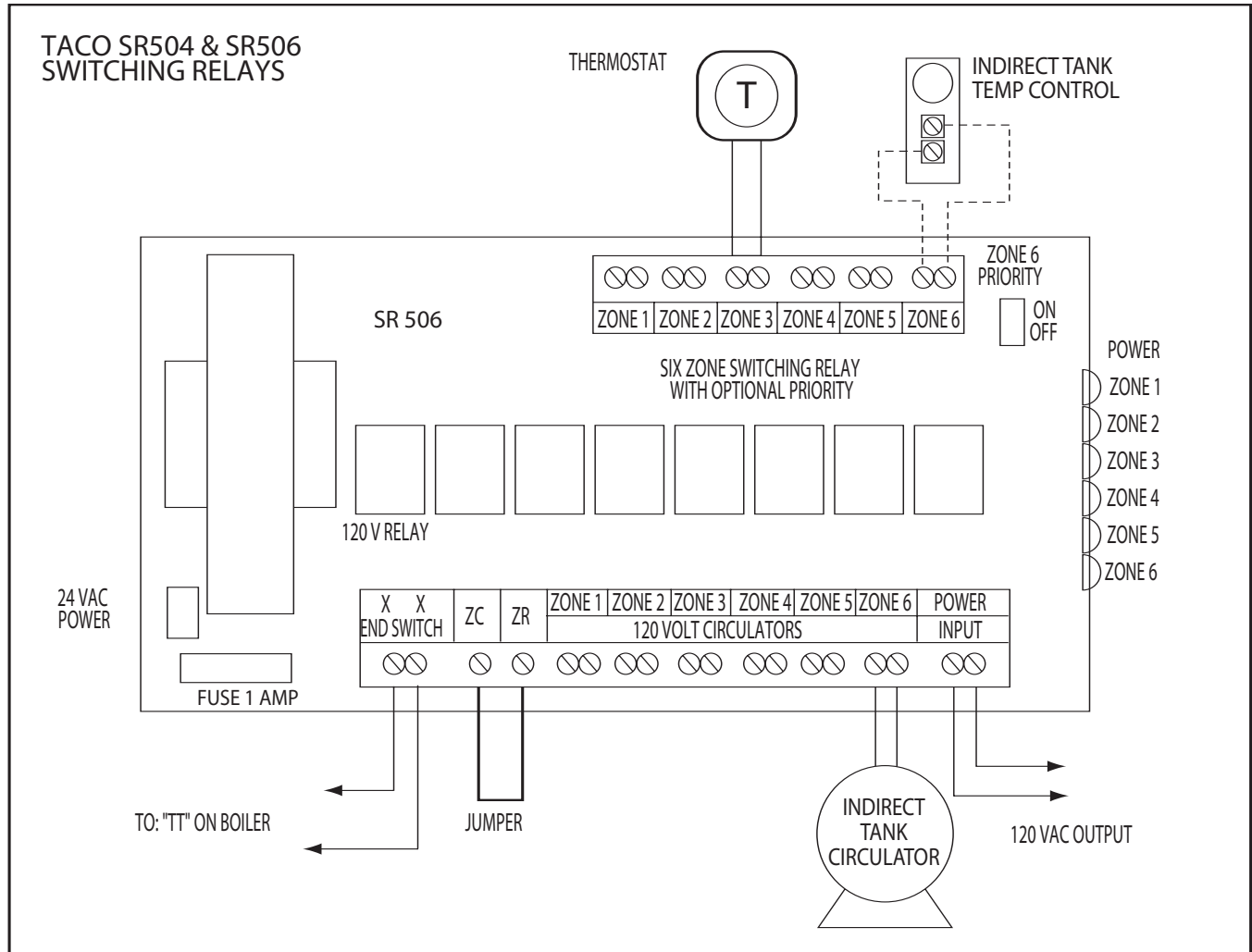

Operation: When any thermostat calls for heat, the appropriate circulator is energized and the isolated end switch (X and X) will start the boiler.

Priority Operation: When zone 6 is switched to the priority setting and is actuated, all other zones will stop operation until zone 6 is satisfied. When zone 6 is not switched to priority, all zones will operate independently.

Jumper Placement: The jumper should be placed between terminals ZC and ZR. Connect the isolated end switch to the aquastat control on the boiler.

Power Input: Connect 120 volt as power input to terminals N and H. Neutral wire to terminal N. Hot wire to terminal H.

V WIRING (cont'd)

Figure 5. Wiring to a gas boiler with circulator zoning

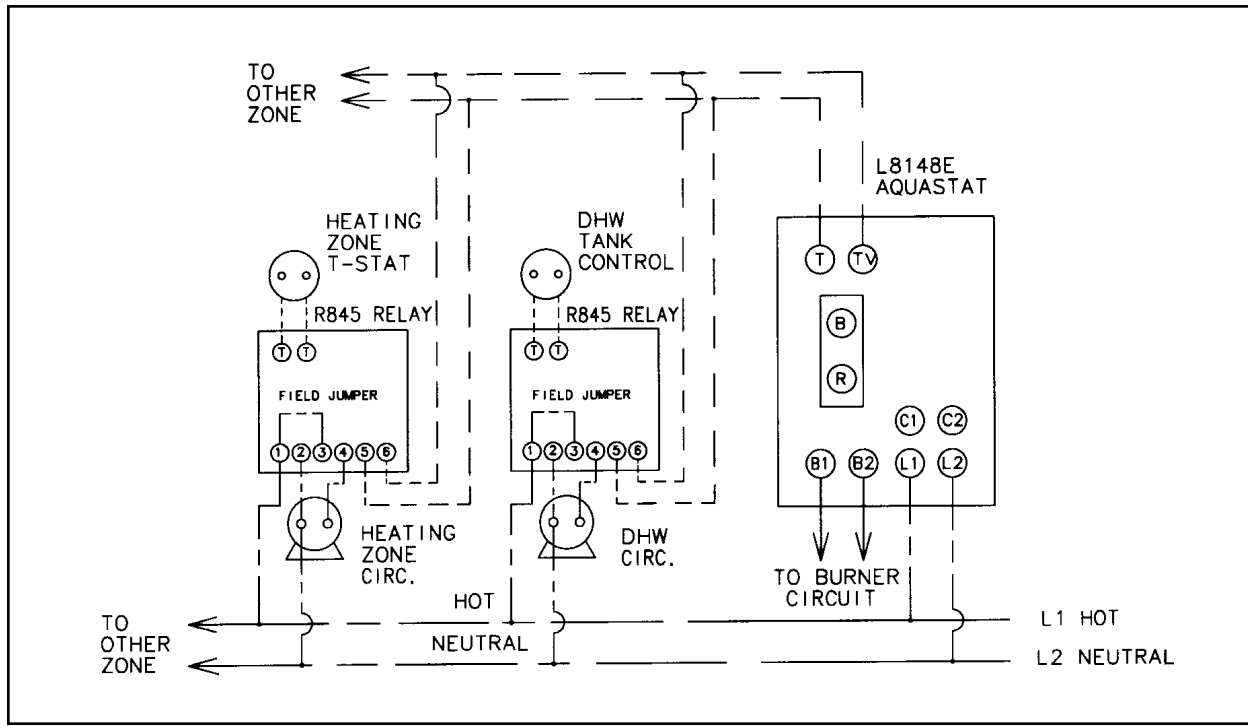
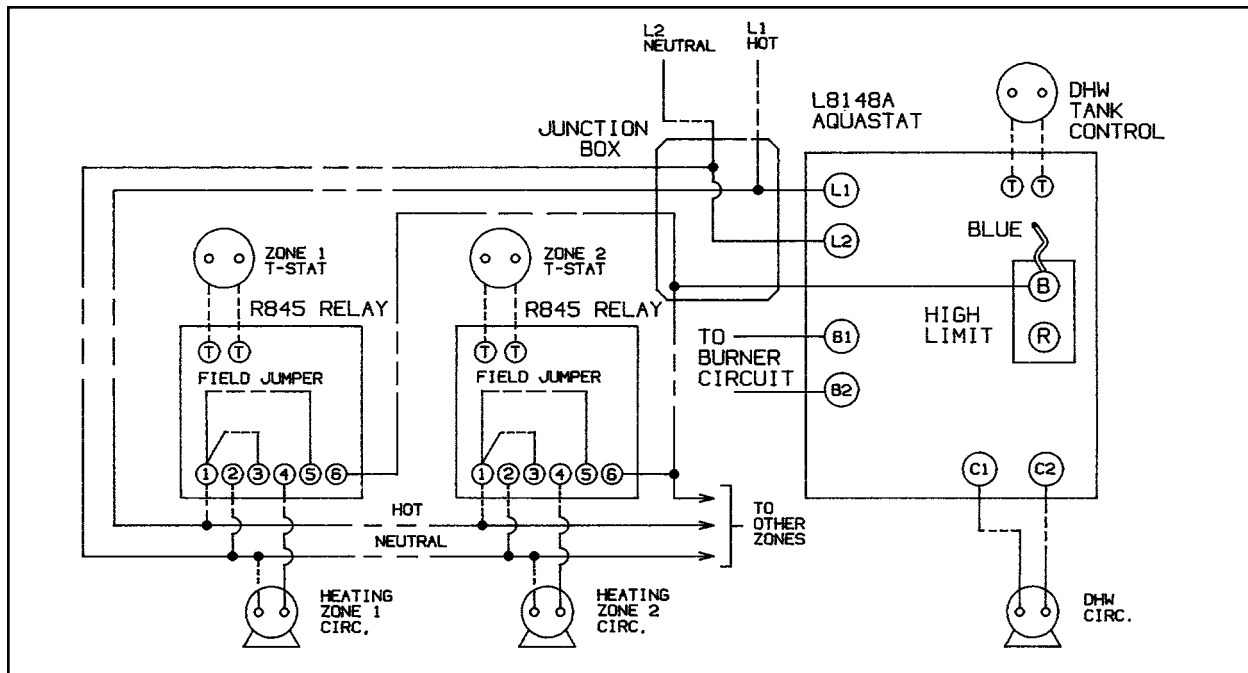

Figure 6. Wiring to an oil boiler with circulator zoning



V WIRING (cont'd)

Circulator zoning wiring (See Fig. 5, 6)

- a) Components must be wired to ensure that only the circulator for each zone is powered on a demand for supply water from that zone.
- b) Multi-zone switching relays are available as an alternative to individual zone relays to simplify the wiring and provide priority on domestic hot water demand.

Zone valve zoning wiring (See Fig. 7, 8)

- a) Components must be wired to ensure that only the zone valve for each zone is powered on a demand for supply water from zone, and that the circulator is powered on a demand from any zone.
- b) The transformer used to power the zone valves must be sized for the load of all the zone valves in system.

Figure 7. Wiring to a gas boiler with zone valves.

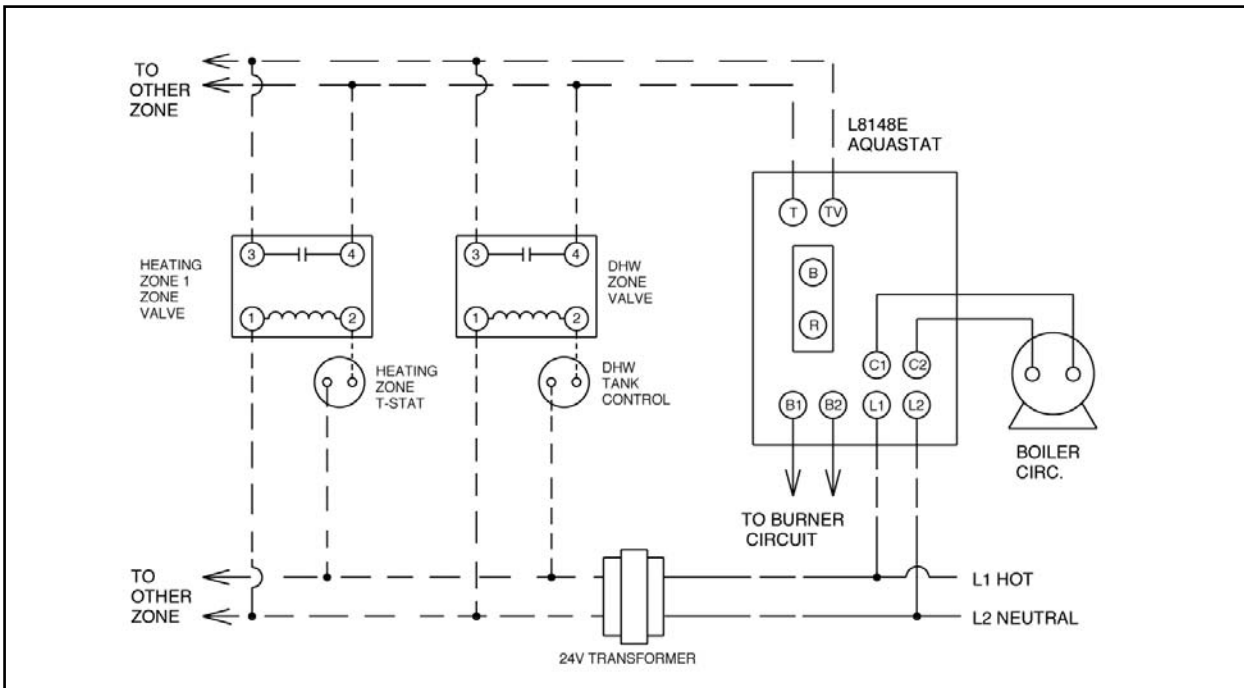
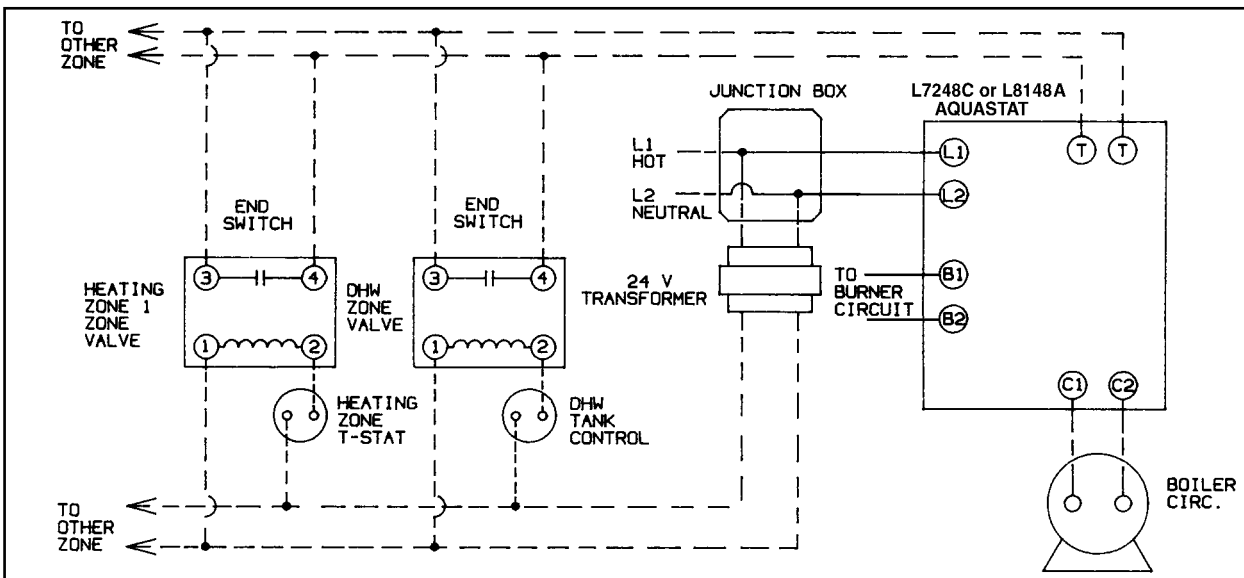

Figure 8. Wiring to an oil boiler with zone valves.



VI MAINTENANCE

To ensure efficient and safe operation, Slant/Fin recommends the servicing of the heater by a competent service technician.

Lime or Sediment Buildup (Every 6 months)

To reduce the buildup of lime or sediment it is recommended that the tank be flushed every six months.

- 1. Drain the tank through the drain valve at the bottom of the tank until the water is clear.
- 2. Inspect the tank for any deposits of lime or sediment.
- 3. Remove lime, scale or deposits using care not to damage the tank lining.

Temperature & Pressure Relief Valve (Every 12 months)

- 1. Before manually testing the T & P valve, make sure the valve is piped in a manner that will not cause harm or damage any surrounding area.
- 2. Manually open the relief valve and allow it to flush out any lime or sediment deposits.
- 3. Allow the relief valve to snap shut, making sure the seal closes properly.

Magnesium - Anti-Corrosion Anodes (No longer than every 12 months)

The Water Heater is provided with two magnesium anti-corrosion anodes, an upper and a bottom anode. Assessment of the condition of the bottom anode can be made by judging the condition of the upper anode.

Removal of the anodes:

- 1. Shut off all power to the heater.
- 2. Close the domestic cold water supply valve.
- 3. Open the household hot water taps.
- 4. Attach a hose to the drain valve located at the bottom of the heater and allow the heater to drain.
- 5. Unscrew the anodes. (Two shiny 1-1/4" Hex Heads on front of tank.)

EXAMINE THE ANODES AND REPLACE IF THE DIAMETER IS LESS THAN .40 inches.

- 6. Replacement of the Anodes -- The use of P.T.F.E. tape is recommended to ensure watertight connection of the anodes.

Failure to inspect the anodes may result in premature failure of the heater.

OWNER INFORMATION:

MODEL _____

SERIAL NO. _____

DATE INSTALLED _____

INSTALLER NAME _____

WHOLESALE NAME _____

ORIGINAL OWNER NAME & ADDRESS _____

ADDITIONAL INFORMATION _____

Slant/Fin[®]

INDIRECT WATER HEATERS

LIMITED WARRANTY FOR SLANT/FIN CORP. INDIRECT-FIRED WATER HEATER

Your Slant/Fin indirect-fired water heater is protected by these warranties.
These warranties are applicable to original residential or commercial purchasers only.

THE FOLLOWING WARRANTIES ARE EXCLUSIVE AND ARE GIVEN AND ACCEPTED IN LIEU OF ANY AND ALL OTHER WARRANTIES, EXPRESS OR IMPLIED, INCLUDING WITHOUT LIMITATION THE IMPLIED WARRANTIES OF MERCHANTABILITY AND FITNESS FOR A PARTICULAR PURPOSE, AND ANY OBLIGATION, LIABILITY, RIGHT, CLAIM OR REMEDY IN CONTRACT OR TORT, WHETHER OR NOT ARISING FROM SLANT/FIN CORP.'S NEGLIGENCE, ACTUAL OR IMPUTED.

THE REMEDIES OF THE ORIGINAL PURCHASER SHALL BE LIMITED TO THOSE PROVIDED HEREIN TO THE EXCLUSION OF ANY OTHER REMEDIES INCLUDING WITHOUT LIMITATION, SPECIAL, INDIRECT, INCIDENTAL AND/OR CONSEQUENTIAL DAMAGES INCLUDING, BUT NOT LIMITED TO PROPERTY DAMAGE, LOST PROFIT, OR DAMAGES ALLEGED TO HAVE BEEN CAUSED BY ANY FAILURE OF SLANT/FIN CORP. SLANT/FIN CORP. TO MEET ANY OBLIGATION UNDER THIS AGREEMENT INCLUDING THE OBLIGATION TO REPAIR AND REPLACE SET FORTH BELOW.

NO AGREEMENT VARYING OR EXTENDING THE FOREGOING WARRANTIES, REMEDIES, OR THIS LIMITATION WILL BE BINDING UPON SLANT/FIN CORP. UNLESS IN WRITING AND SIGNED BY A DULY AUTHORIZED OFFICER OF SLANT/FIN CORP. SLANT/FIN CORP. DOES NOT ASSUME OR AUTHORIZE ANY OTHER PERSON TO ASSUME FOR IT ANY OTHER LIABILITY IN CONNECTION WITH THE SALE OF ITS PRODUCTS.

THIS WARRANTY EXTENDS ONLY TO THE FIRST (ORIGINAL) RETAIL PURCHASER OF THE TANK AND ONLY WHILE THE TANK IS OWNED BY THAT PURCHASER AND REMAINS AT ITS ORIGINAL LOCATION. CHANGE IN OWNERSHIP OR RELOCATION OF THE TANK SHALL FORTHWITH TERMINATE THIS WARRANTY WITHOUT FURTHER NOTICE.

WARRANTY COVERAGE FOR RESIDENTIAL USAGE - 7 YEARS

The Warranties listed in this section shall apply to Slant/Fin Corp. indirect-fired water heaters used in a residential setting by **original purchasers only**. A "residential setting" as used herein shall mean usage either (a) in a single family dwelling in which the original consumer purchaser of the indirect-fired water heater resides on a permanent basis or (b) in a multiple family dwelling provided that such indirect-fired water heater services only one family unit in a multiple family dwelling; provided that the term "residential setting" shall not include any usage of the indirect-fired water heater above 150 degrees Fahrenheit.

During the specified warranty period of the indirect-fired water heater, Slant/Fin Corp. will repair or replace, at its option, without charge, any indirect-fired water heater having a defect or malfunction that results in a water leak from the outside jacket, inner tank, or heat exchanger as a result of normal use and service. It is expressly agreed between Slant/Fin Corp. and the original residential purchaser that repair or replacement is the exclusive and sole remedy of the original purchaser.

Any claim under this warranty must be verified by an authorized Slant/Fin Corp. representative: if the claim is found to be valid, SLANT/FIN CORP. will repair or replace the tank as set forth herein, within a reasonable time after verification. If Slant/Fin Corp. chooses in its discretion to repair any indirect-fired water heater for which there is a valid warranty claim, Slant/Fin Corp. shall provide parts that are compatible with the subject indirect-fired water heater, which parts need not be identical to the original. If Slant/Fin Corp. chooses, in its discretion, to replace any indirect-fired water heater for which there is a valid warranty claim, Slant/Fin Corp. shall replace the subject indirect-fired water heater with the same model or, if such model is not available, with a model which is, in Slant/Fin Corp.'s reasonable judgment, the nearest compatible model available at the time of replacement.

If Slant/Fin Corp. is unable to repair or replace or otherwise comply with its liability under these warranties, after a reasonable number of attempts, then the original consumer purchaser's sole and exclusive remedy for such breach shall be either a replacement product or a full refund of the purchase price (exclusive of freight, labor and installation), as determined by Slant/Fin Corp..

If the original purchaser cannot provide proof of purchase then SLANT/FIN CORP. may request proof of residency dating back to the date of manufacture of the tank. In such case the warranty period will begin from the date of manufacture as determined by the tank serial number.

WARRANTY COVERAGE FOR COMMERCIAL USAGE - (THREE YEARS)

The warranties listed in this section shall apply to Slant/Fin Corp. indirect-fired water heaters used in a commercial setting by original consumer purchasers only. A "commercial setting" as used herein shall mean any usage not falling within the above definition of a "residential setting". An indirect-fired water heater shall be deemed to be used in a "commercial setting" if at any time it is operated at a temperature above 150 degrees Fahrenheit.

If at the time of a request for service the original business purchaser cannot provide a copy of the original sales receipt, installation bill, or equivalent document, then the warranty period for the indirect-fired water heater shall be five (3) years from the date of manufacture of the indirect-fired water heater as determined by the tank serial number.

REPLACEMENT TANK - WARRANTY RESIDENTIAL OR COMMERCIAL APPLICATION

For either a residential or commercial application, the following applies to both when a replacement tank is provided for a tank found to be under warranty. The replacement tank warranty assumes the remaining warranty period left from the original tank purchased.

WHAT IS NOT COVERED BY EITHER OF THESE WARRANTIES

These warranties are void and shall not apply under the following circumstances:

1. The water heater was not installed or repaired by a heating contractor whose principal occupation is the sale, installation and repair of plumbing, heating and/or air conditioning equipment.
2. These warranties cannot be considered as a guarantee of workmanship of an installer connected with the installation of the water heater, or as imposing on Slant/Fin Corp. liability of any nature for unsatisfactory performance as result of faulty workmanship in the installation or repair which liability is expressly disclaimed.
3. The failure or malfunction results from improper or negligent operation, abuse, misuse or maintenance or unauthorized alteration.
4. Malfunctions resulting from, or repairs necessitated by, uses of the indirect-fired water heater for purposes other than that for which it was designed, or resulting from flood, fire, wind, lightning, freezing or any other natural disaster or act of God, an act of destruction, theft or accident.
5. The original serial number on the indirect-fired water heater or component thereof cannot be readily determined.
6. Any indirect-fired water heater is installed in a setting containing any type of water softener system that is not installed and maintained in accordance with the manufacturer's specifications.
7. The indirect-fired water heater is used for non-potable applications such as pool or process heating.
8. The failure or malfunction results from failure to keep the tank full of potable water, free to circulate at all times and with the tank free of damaging water sediment or scale deposits.
9. Components of an indirect-fired water heater which are not defective, but must be replaced during the warranty period as a result of reasonable wear and tear.
10. Indirect-fired water heaters which are repaired or altered without prior written approval of Slant/Fin Corp. so as to affect adversely their reliability.
11. Slant/Fin Corp. indirect-fired water heaters installed outside of the United States and Canada.
12. Service calls not involving any malfunction or defects and maintenance in the ordinary course.
13. Components of an indirect-fired water heater which are not manufactured expressly for Slant/Fin Corp.; such components are subject only to those warranties, if any, given by their manufacturers. Slant/Fin Corp. does not adopt and has no responsibility for those warranties.
14. Any tank that does not have installed a new temperature and pressure relief valve bearing the American Society of Mechanical Engineers (A.S.M.E.) listing at the time of installation.

FURTHER LIMITATIONS OF WARRANTIES AND REMEDIES

These warranties give you specific legal rights, and you may also have other rights which vary from state to state. Some states do not allow the exclusion or limitation of incidental or consequential damages, so this limitation or exclusion may not apply to you. These are the only written warranties applicable to Slant/Fin Corp. indirect-fired water heaters manufactured for and sold by Slant/Fin Corp.. Slant/Fin Corp. neither assumes nor authorizes anyone to assume for it any other obligation or liability in connection with said indirect-fired water heaters. **This warranty does not cover expenses or labor for disassembly, removal, shipment reassembly or reinstallation; the original purchaser will be responsible for such costs.** Slant/Fin Corp.'s performance under these warranties may be contingent on shipment of components or equipment from suppliers. Slant/Fin Corp. shall not be liable for any failure or delay in delivery due to any cause beyond its control including without limitation, strike, labor stoppage, a natural disaster (such as earthquake, flood, fire or storm), political insurrection or the unavailability of components, equipment or supplies.

MAKING A WARRANTY CLAIM

TO FILE A CLAIM UNDER THESE WARRANTIES CONTACT SLANT/FIN CORP. INC. AT THIS ADDRESS:
100 FOREST DRIVE, GREENVALE, NY 11548 OR CALL SLANT/FIN CORP. AT (516) 484-2600 AND ASK FOR CUSTOMER SERVICE. At the time a claim is filed, the original purchaser must present a copy of the original sales receipt, installation bill, proof of delivery or equivalent documents evidencing both ownership of the indirect-fired water heater and installation in the dwelling or commercial property owned by the original purchaser. This warranty is to be governed by and construed in accordance with the laws of the State of New York without regard to the principles of conflict of laws. SLANT/FIN CORP. RESERVES THE RIGHT TO CHANGE SPECIFICATIONS OR DISCONTINUE MODELS WITHOUT NOTICE.